

	1ST AXLE	2ND AXLE	3RD AXLE	GROSS MASS
CHASSIS MASS	4,095	1,682.5	1,682.5	7,460
EQUIPPED VEHICLE MASS	5,955	4,700	4,700	15,355
FULL WATER	6,050	6,650	6,650	19,350
FULL DEBRIS	6,050	7,400	7,400	20,850
MAXIMUM ALLOWABLE MASS	6,500	8,250	8,250	22,500

max mass equipped vehicle	15,355
Debris Volume	5,500L
Water Volume	4,000L
Tank Diameter	1,800mm

ISUZU FXY 1500 6X4

BASE MASS	7,640KG
GVM	22,500KG
1ST AXLE	6,500KG
2ND AXLE	8,250KG
3RD AXLE	8,250KG

GENERAL NOTES:
UNLESS OTHERWISE SPECIFIED: DRAWING
STANDARD: A.S.1100 ALL DIMENSIONS IN mm
THIS DRAWING AND THE INFORMATION IT
CONTAINS MUST NOT BE DUPLICATED WITHOUT
PERMISSION OF BELL ENVIRONMENTAL. ALL
COPIES MUST BE RETURNED



88-90 Berkshire Rd.
North Sunshine
Victoria 3020
Ph. (03) 9311 8460
FAX (03) 9311 5238
ABN. 26 306 957 261

NAME	DATE	MATERIAL:
DRAWN PJB	15/03/2018	THICKNESS:
CHK'D		FINISH:
APPV'D		SCALE:

SCALE:
1:20

CLIENT: Bell Environmental
JOB TITLE:

TITLE: 6x4 Combination Unit

DWG NO.: VC-001

WEIGHT: 8021

A2

REV 0

SHEET 1 OF 5

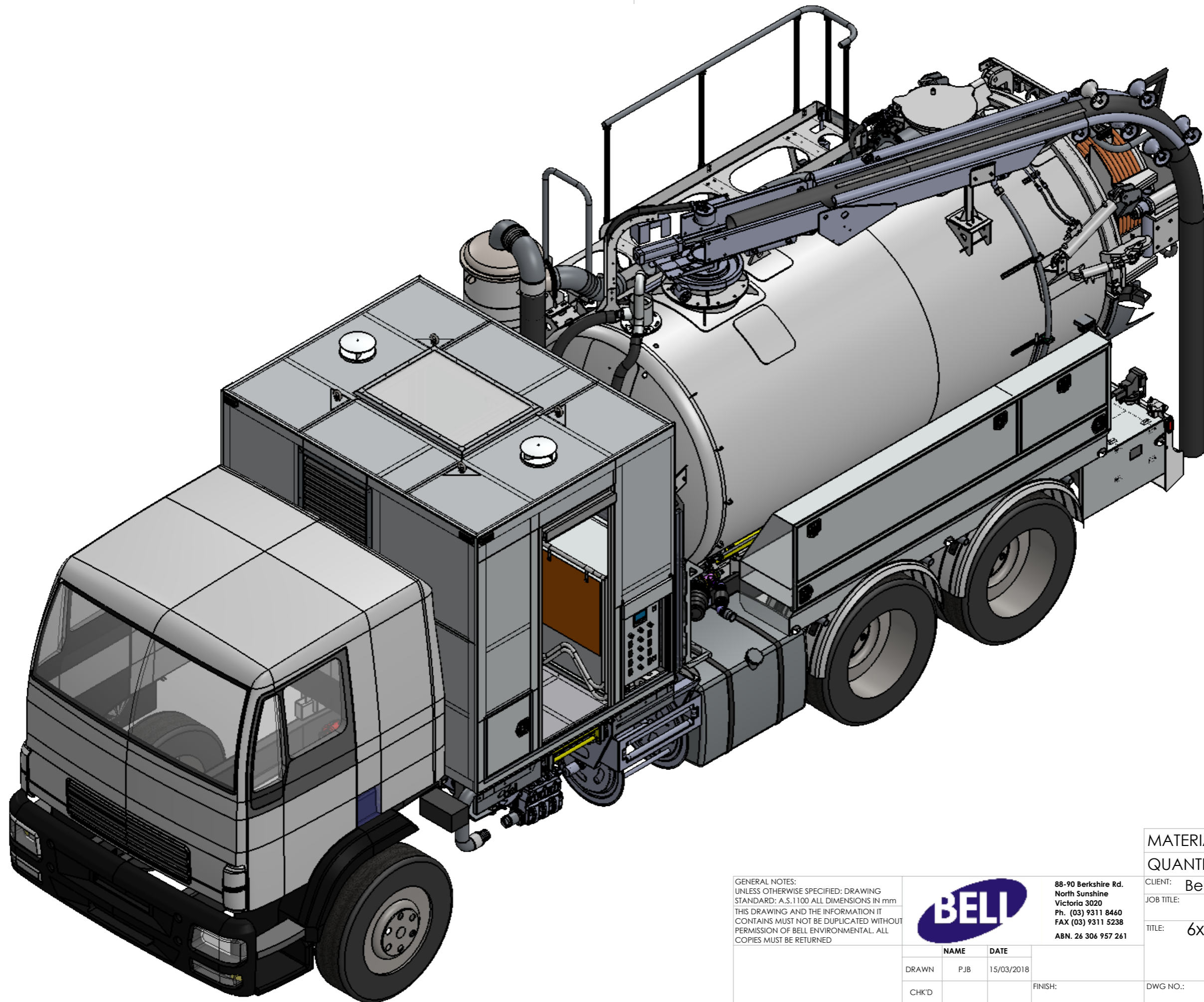

GENERAL NOTES:
 UNLESS OTHERWISE SPECIFIED: DRAWING
 STANDARD: A.S.1100 ALL DIMENSIONS IN mm.
 THIS DRAWING AND THE INFORMATION IT
 CONTAINS MUST NOT BE DUPLICATED WITHOUT
 PERMISSION OF BELL ENVIRONMENTAL. ALL
 COPIES MUST BE RETURNED



88-90 Berkshire Rd.
 North Sunshine
 Victoria 3020
 Ph. (03) 9311 8460
 FAX (03) 9311 5238
 ABN. 26 306 957 261

NAME	DATE
DRAWN PJB	15/03/2018
CHK'D	
APPVD	

FINISH:
 SCALE:
 1:25



MATERIAL:	
QUANTITY: 1	
CLIENT: Bell Environmental	A3
JOB TITLE:	
TITLE: 6x4 Combination Unit	
DWG NO.: VC-001	REV
WEIGHT: 8021 kg	SHEET 2 OF 5

1 2 3 4 5 6 7 8

A
B
C
D
E
F

1 2 3 4 5 6 7 8

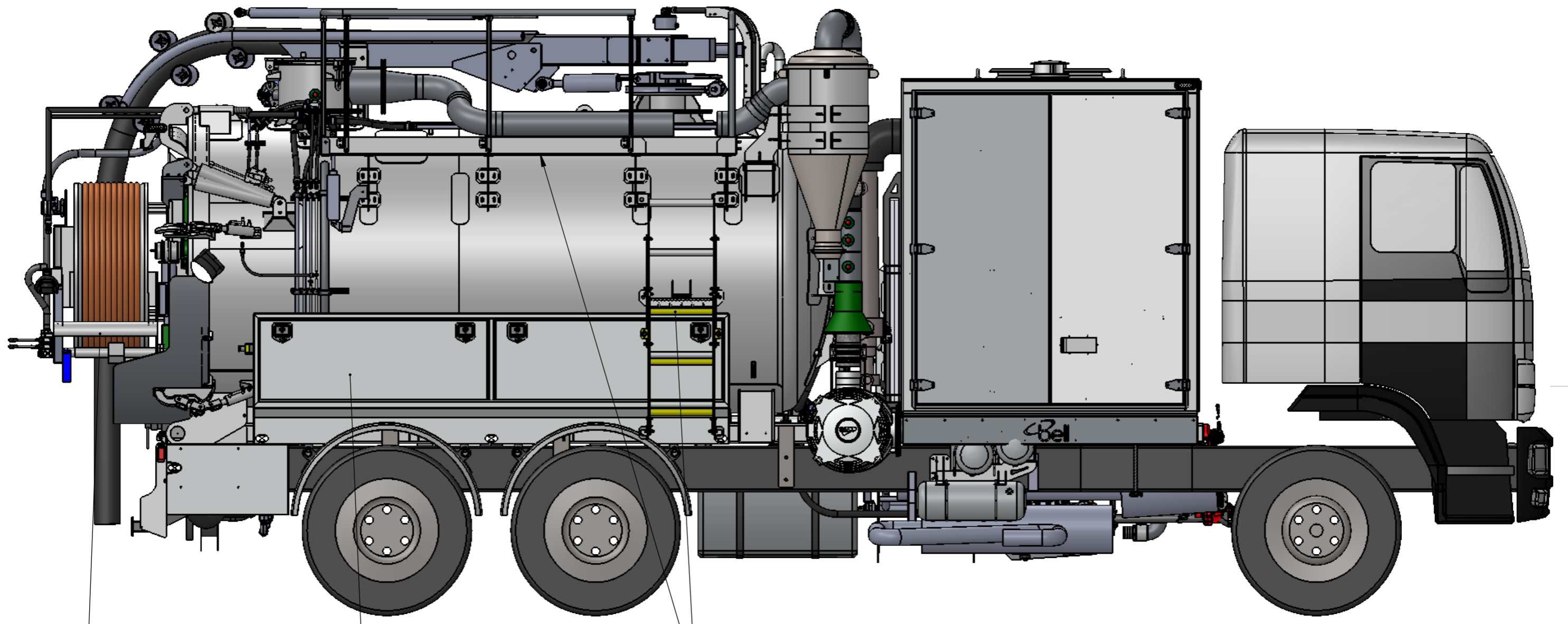

Hose Reel

Stowage

Access Ladder and Platform

GENERAL NOTES:
UNLESS OTHERWISE SPECIFIED: DRAWING
STANDARD: A.S.1100 ALL DIMENSIONS IN mm.
THIS DRAWING AND THE INFORMATION IT
CONTAINS MUST NOT BE DUPLICATED WITHOUT
PERMISSION OF BELL ENVIRONMENTAL. ALL
COPIES MUST BE RETURNED



88-90 Berkshire Rd.
North Sunshine
Victoria 3020
Ph. (03) 9311 8460
FAX (03) 9311 5238
ABN. 26 306 957 261

NAME	DATE
DRAWN PJB	15/03/2018
CHK'D	
APPVD	

FINISH:

SCALE:
1:25



MATERIAL:

QUANTITY: 1

CLIENT: Bell Environmental

JOB TITLE:

TITLE: 6x4 Combination Unit

DWG NO.:

VC-001

WEIGHT: 8021 kg

SHEET 3 OF 5

A3

REV

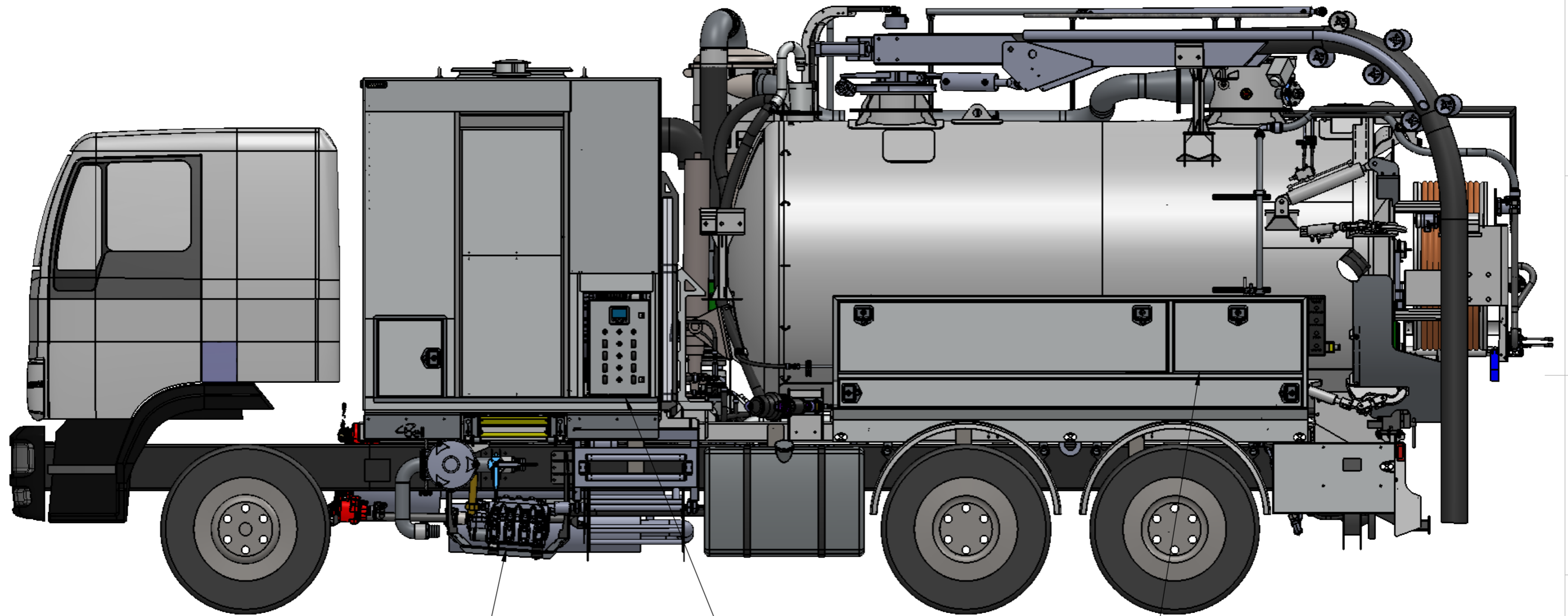

Water Pump

Control Box

Stowage

GENERAL NOTES:
UNLESS OTHERWISE SPECIFIED: DRAWING
STANDARD: A.S.1100 ALL DIMENSIONS IN mm.
THIS DRAWING AND THE INFORMATION IT
CONTAINS MUST NOT BE DUPLICATED WITHOUT
PERMISSION OF BELL ENVIRONMENTAL. ALL
COPIES MUST BE RETURNED



88-90 Berkshire Rd.
North Sunshine
Victoria 3020
Ph. (03) 9311 8460
FAX (03) 9311 5238
ABN. 26 306 957 261

NAME	DATE
DRAWN PJB	15/03/2018
CHK'D	
APPVD	

FINISH:
SCALE:
1:25



MATERIAL:	
QUANTITY: 1	
CLIENT: Bell Environmental	A3
JOB TITLE:	
TITLE: 6x4 Combination Unit	
DWG NO.: VC-001	REV
WEIGHT: 8021 kg	SHEET 4 OF 5

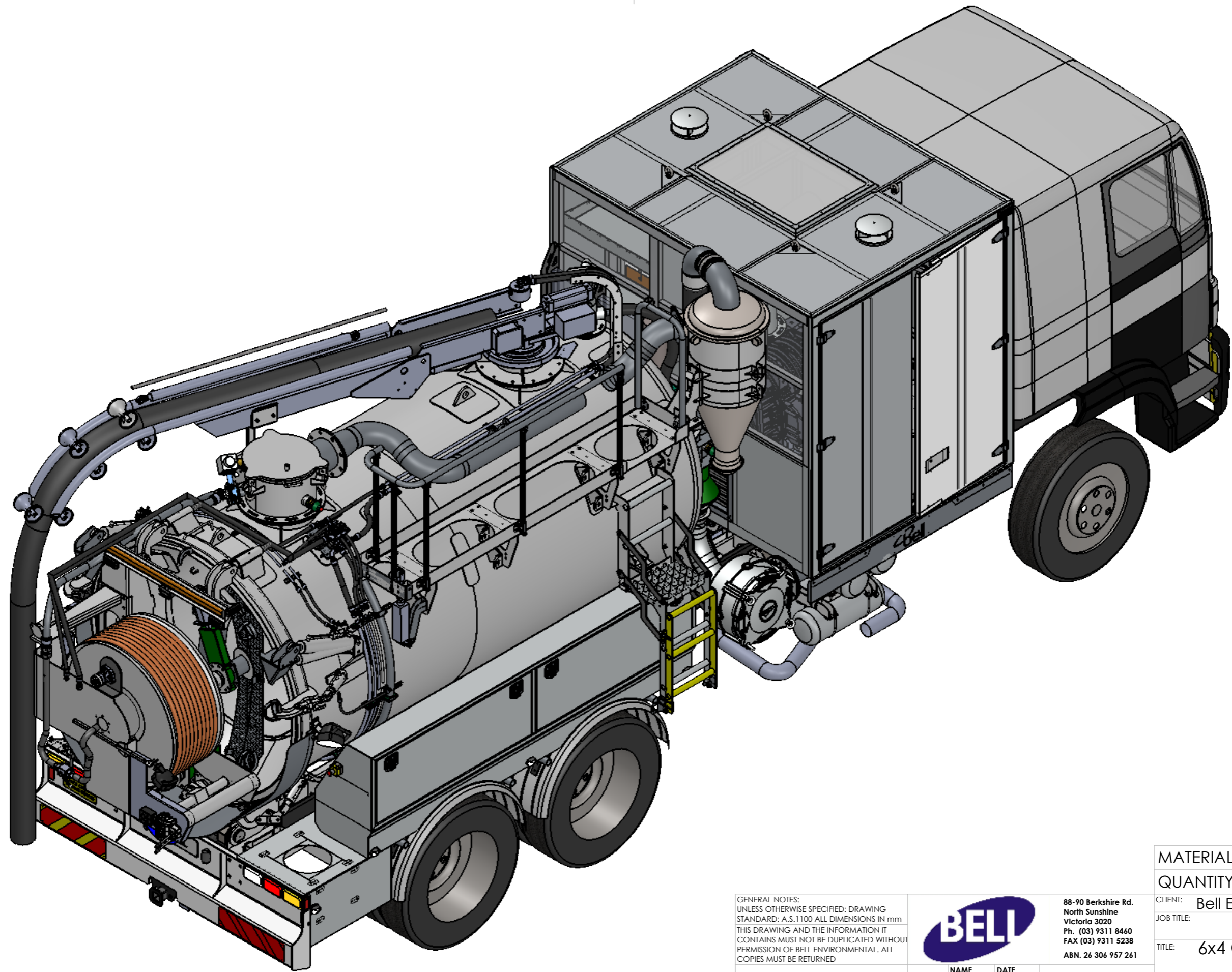

GENERAL NOTES:
 UNLESS OTHERWISE SPECIFIED: DRAWING
 STANDARD: A.S.1100 ALL DIMENSIONS IN mm.
 THIS DRAWING AND THE INFORMATION IT
 CONTAINS MUST NOT BE DUPLICATED WITHOUT
 PERMISSION OF BELL ENVIRONMENTAL. ALL
 COPIES MUST BE RETURNED



88-90 Berkshire Rd.
 North Sunshine
 Victoria 3020
 Ph. (03) 9311 8460
 FAX (03) 9311 5238
 ABN. 26 306 957 261

NAME	DATE
DRAWN PJB	15/03/2018
CHK'D	
APPVD	

FINISH:
 SCALE:
 1:25

MATERIAL:	
QUANTITY: 1	
CLIENT: Bell Environmental	A3
JOB TITLE:	
TITLE: 6x4 Combination Unit	
DWG NO.: VC-001	REV
WEIGHT: 8021 kg	SHEET 5 OF 5