

GENERAL NOTES:  
 UNLESS OTHERWISE SPECIFIED: DRAWING STANDARD: A.S.1100 ALL DIMENSIONS IN mm.  
 THIS DRAWING AND THE INFORMATION IT CONTAINS MUST NOT BE DUPLICATED WITHOUT PERMISSION OF BELL ENVIRONMENTAL. ALL COPIES MUST BE RETURNED



88-90 Berkshire Rd.  
 North Sunshine  
 Victoria 3020  
 Ph. (03) 9311 8460  
 FAX (03) 9311 5238  
 ABN. 26 306 957 261

NAME	DATE
DRAWN	6/03/2018
CHK'D	
APPVD	

FINISH:  
 SCALE: 1:30

MATERIAL:	
QUANTITY:0	
CLIENT: Bell Environmental	A3
JOB TITLE:	
TITLE: Combo Light	
DWG NO.: LC-001	REV 10
WEIGHT: 88701 kg	SHEET 1 OF 5

REVISIONS			
REV.	DESCRIPTION	DATE	APPROVED
1	relocated control panel; increased stowage room access door	6/02/2018	

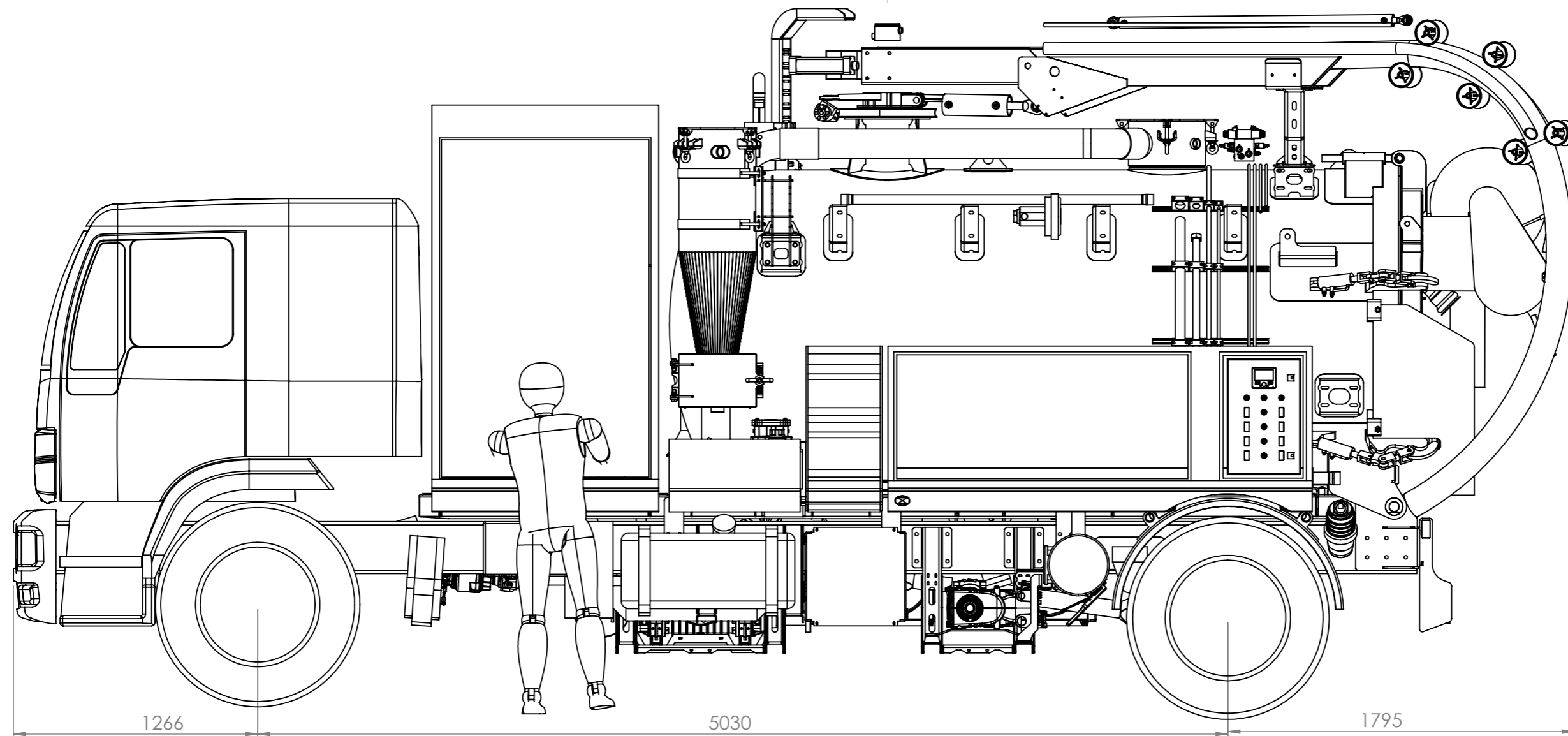

	FRONT AXLE	REAR AXLE	GROSS MASS
CHASSIS MASS	3295	1845	5140
EQUIPPED VEHICLE MASS	4770	5170	9940
WATER	5250	7690	12940
PAYLOAD	5400	8540	13940
MAXIMUM ALLOWABLE MASS	6000	9000	15000

GENERAL VEHICLE SPECIFICATIONS	
PAYLOAD VOLUME	4000L
WATER VOLUME	3000L
OVERALL LENGTH	8.3M
VACUUM PUMP	JUROP PVT400 @ 1450CFM
WATER PUMP	PRATISSOLI KF36 @ 150LPM; 1900PSI
HOSE REEL	110M 3/4" HOSE
BOOM	5" SUCTION HOSE

GENERAL NOTES:  
UNLESS OTHERWISE SPECIFIED: DRAWING STANDARD: A.S.1100 ALL DIMENSIONS IN mm.  
THIS DRAWING AND THE INFORMATION IT CONTAINS MUST NOT BE DUPLICATED WITHOUT PERMISSION OF BELL ENVIRONMENTAL. ALL COPIES MUST BE RETURNED



88-90 Berkshire Rd.  
North Sunshine  
Victoria 3020  
Ph. (03) 9311 8460  
FAX (03) 9311 5238  
ABN. 26 306 957 261

NAME	DATE
DRAWN	6/03/2018
CHK'D	
APPVD	

FINISH:  
SCALE:  
1:25



MATERIAL:	
QUANTITY:0	
CLIENT:	A3
JOB TITLE:	
TITLE:	Combo Light
DWG NO.:	LC-001
REV	1
WEIGHT: 88701 kg	SHEET 2 OF 5

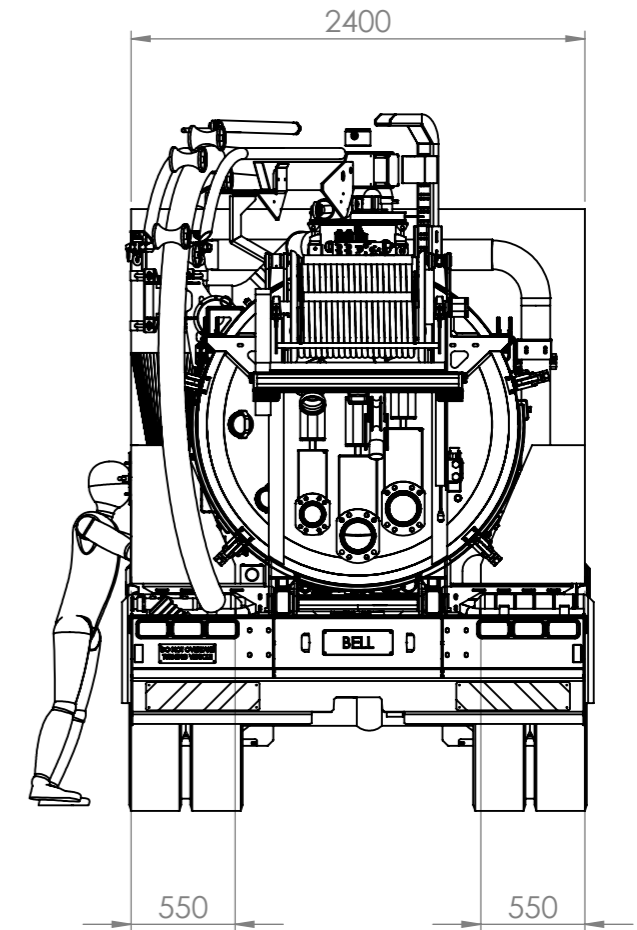
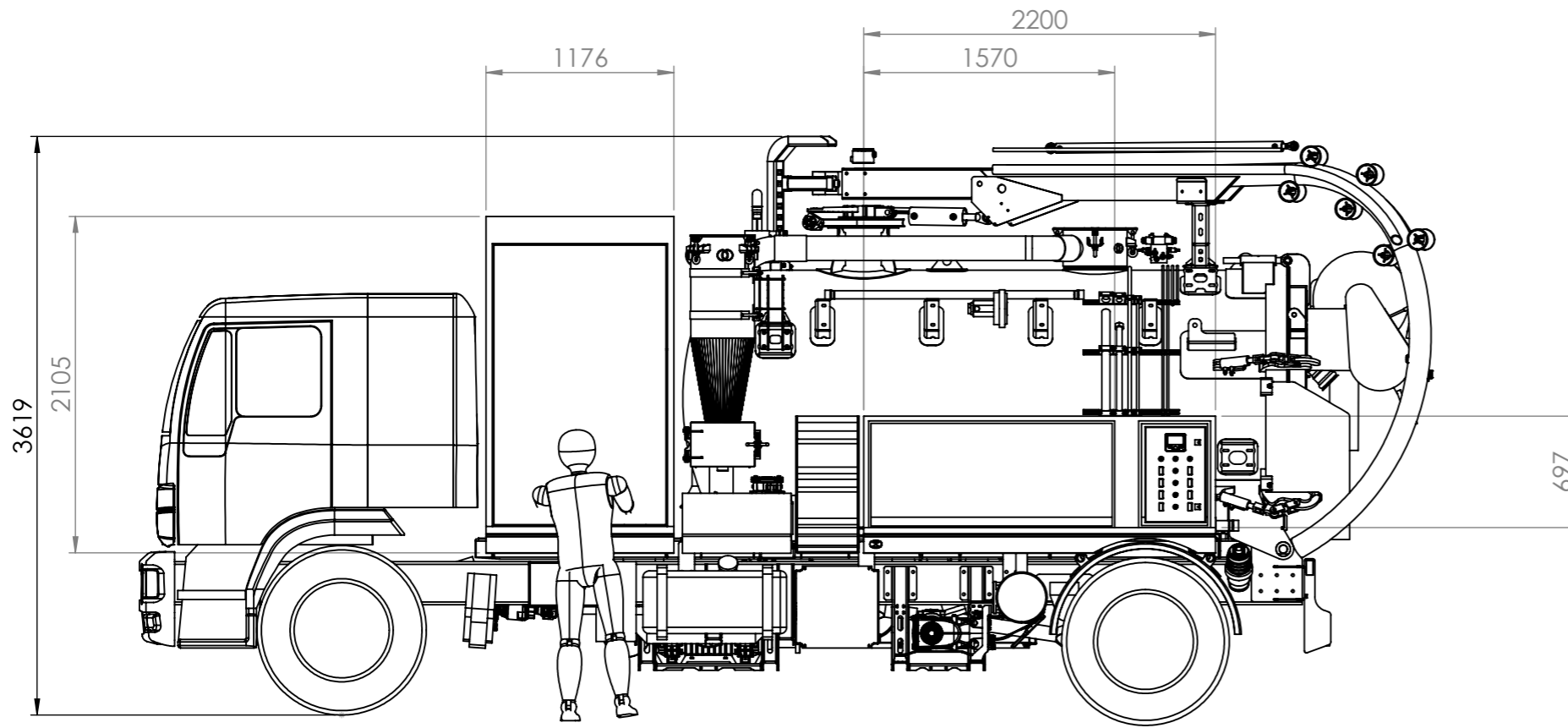

GENERAL NOTES:  
UNLESS OTHERWISE SPECIFIED: DRAWING STANDARD: A.S.1100 ALL DIMENSIONS IN mm.  
THIS DRAWING AND THE INFORMATION IT CONTAINS MUST NOT BE DUPLICATED WITHOUT PERMISSION OF BELL ENVIRONMENTAL. ALL COPIES MUST BE RETURNED



88-90 Berkshire Rd.  
North Sunshine  
Victoria 3020  
Ph. (03) 9311 8460  
FAX (03) 9311 5238  
ABN. 26 306 957 261

	NAME	DATE
DRAWN		6/03/2018
CHK'D		
APPVD		

FINISH:  
SCALE: 1:40

MATERIAL:	
QUANTITY:0	
CLIENT:	
JOB TITLE:	A3
TITLE:	Combo Light
DWG NO.:	LC-001
REV	1
WEIGHT: 88701 kg	SHEET 3 OF 5

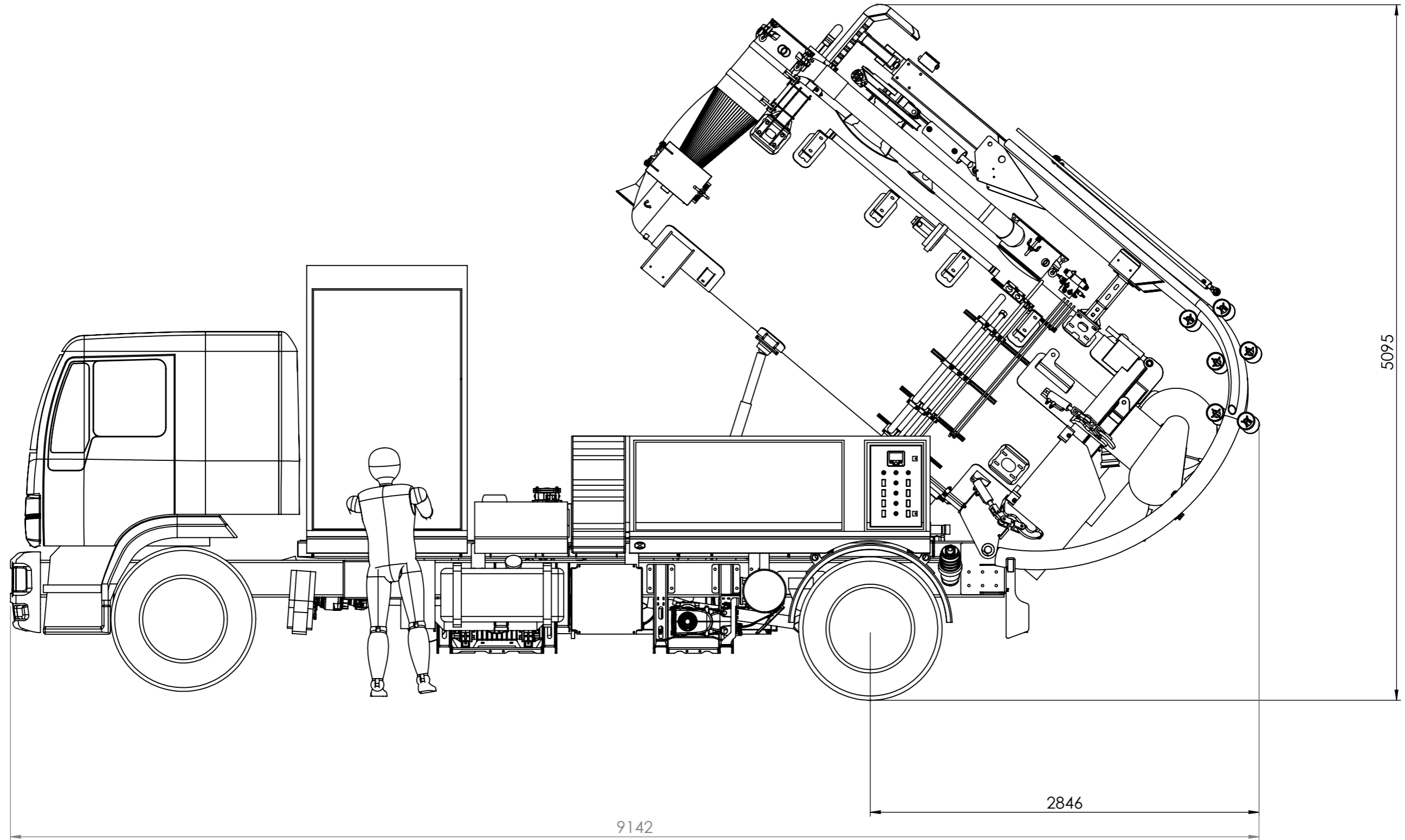

GENERAL NOTES:  
 UNLESS OTHERWISE SPECIFIED: DRAWING  
 STANDARD: A.S.1100 ALL DIMENSIONS IN mm.  
 THIS DRAWING AND THE INFORMATION IT  
 CONTAINS MUST NOT BE DUPLICATED WITHOUT  
 PERMISSION OF BELL ENVIRONMENTAL. ALL  
 COPIES MUST BE RETURNED



88-90 Berkshire Rd.  
 North Sunshine  
 Victoria 3020  
 Ph. (03) 9311 8460  
 FAX (03) 9311 5238  
 ABN. 26 306 957 261

NAME	DATE
DRAWN	6/03/2018
CHK'D	
APPVD	

FINISH:  
 SCALE:  
 1:30

MATERIAL:	
QUANTITY:0	
CLIENT:	
JOB TITLE:	A3
TITLE:	Combo Light - Tank Tipped
DWG NO.:	LC-001
REV	1
WEIGHT: 88701 kg	SHEET 4 OF 5



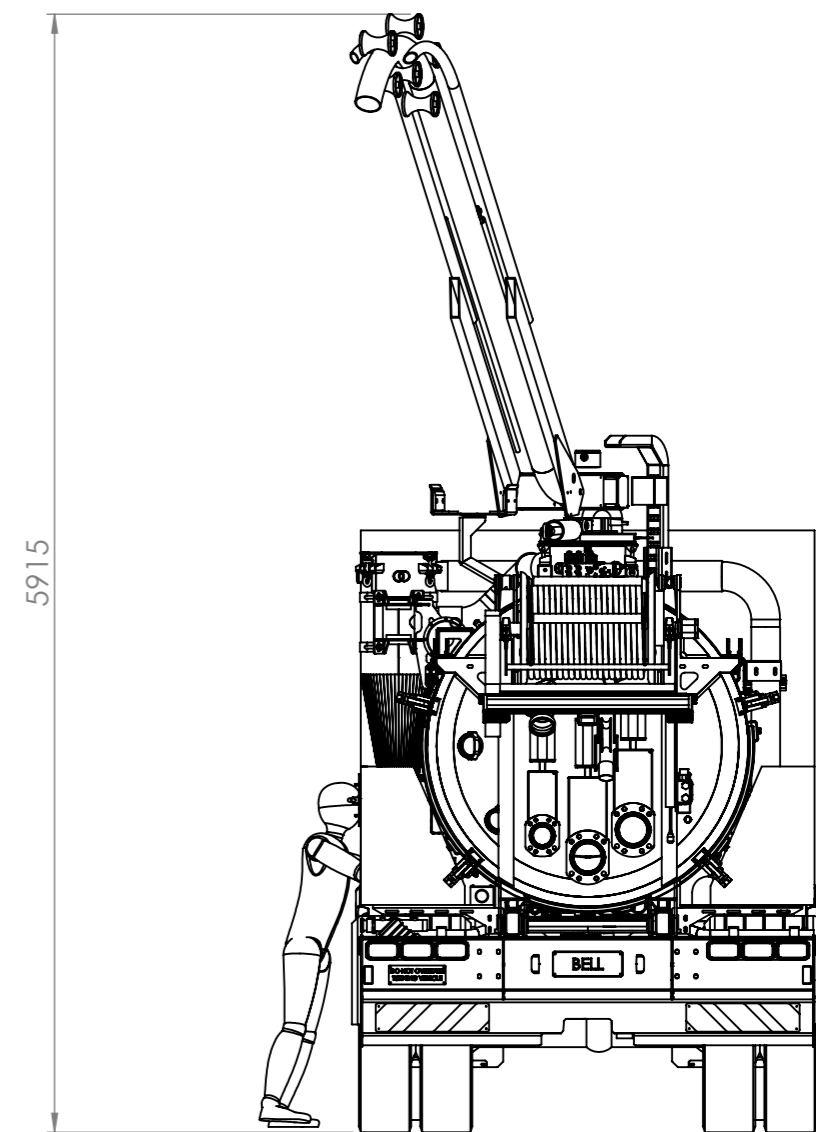
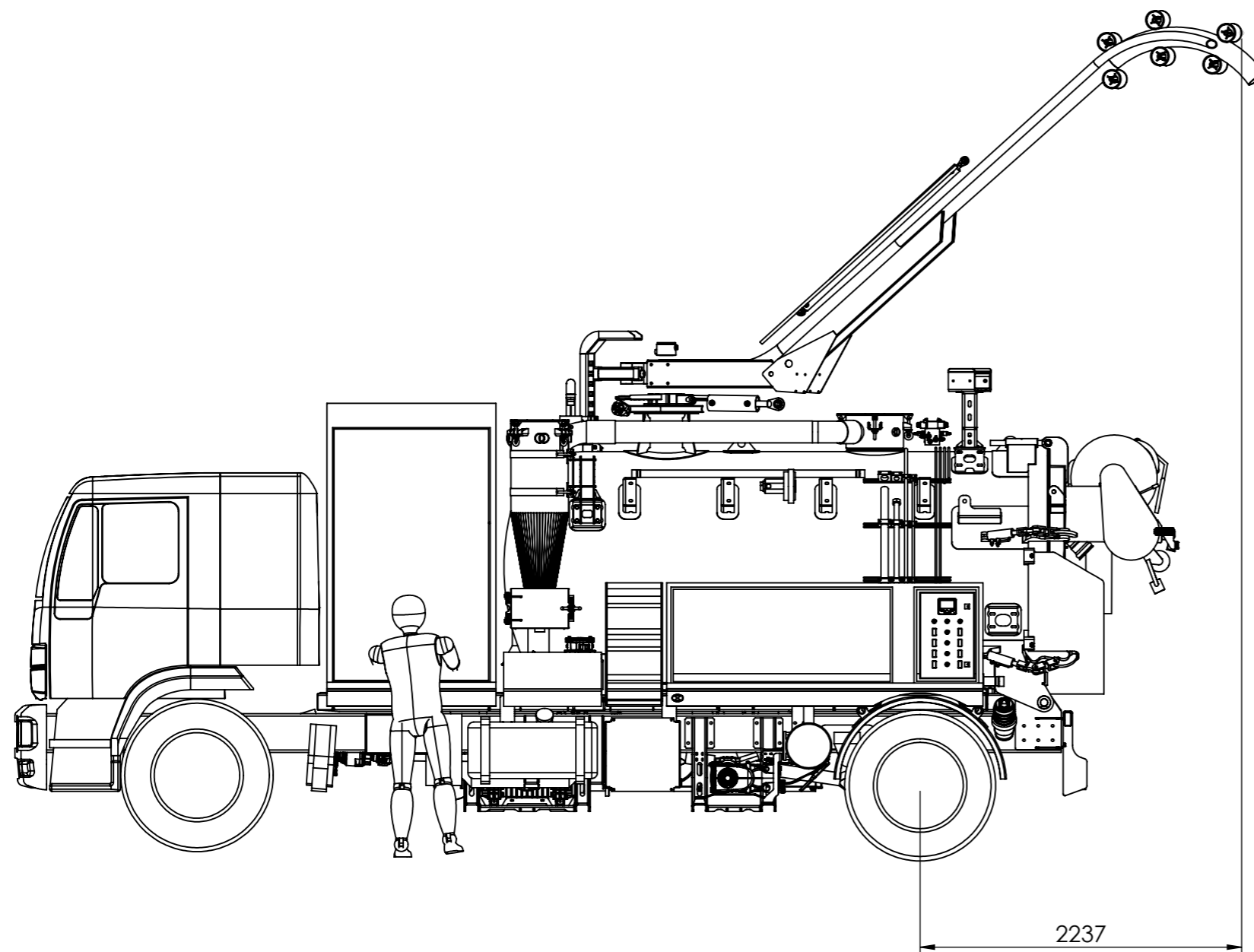

GENERAL NOTES:  
UNLESS OTHERWISE SPECIFIED: DRAWING  
STANDARD: A.S.1100 ALL DIMENSIONS IN mm.  
THIS DRAWING AND THE INFORMATION IT  
CONTAINS MUST NOT BE DUPLICATED WITHOUT  
PERMISSION OF BELL ENVIRONMENTAL. ALL  
COPIES MUST BE RETURNED



88-90 Berkshire Rd.  
North Sunshine  
Victoria 3020  
Ph. (03) 9311 8460  
FAX (03) 9311 5238  
ABN. 26 306 957 261

NAME	DATE
DRAWN	6/03/2018
CHK'D	
APPVD	

FINISH:  
SCALE:  
1:40



MATERIAL:  
QUANTITY:0

CLIENT:  
JOB TITLE:

A3

TITLE: Combo Light - Boom Up  
& Extended

DWG NO.:

LC-001

REV  
1

WEIGHT: 88701 kg

SHEET 5 OF 5